

STILETTO 18™



Blizzard Lighting, LLC
www.blizzardlighting.com
Waukesha, WI USA
Copyright (c) 2015

TABLE OF CONTENTS

Stiletto™ Z18 Moving Head Fixture	1
1. Getting Started	3
What's In The Box?	3
Getting It Out Of The Box	3
Powering Up!	3
Getting A Hold Of Us	3
Safety Instructions (Don't Stick Your Hand In The Toaster!)	4
2. Meet The Stiletto™ Z18	5
Main Features	5
Control	5
DMX Quick Reference	5
The Stiletto™ Z18 Pin-up Picture	6
3. Setup	7
Fuse Replacement	7
Connecting A Bunch Of Stiletto™ Z18 Fixtures	7
Data/DMX Cables	7
Cable Connectors	8
3-Pin??? 5-Pin??? Huh?	8
Take It To The Next Level: Setting up DMX Control	8
Fixture Linking (Master/Slave Mode)	9
Mounting/Rigging	9
Mounting Points	10
Clamp Mounting	11
4. Operating Adjustments	12
The Control Panel	12
Control Panel Menu Structure	13
DMX Mode	13
Set The DMX Starting Address	13
DMX Channel Mode	13
Slave Mode	13
Personal (Customized) Settings	14
Revert Custom Settings	14
Auto, Stand-Alone, Sound Active Modes	14
Auto Mode	14
Sound Active Mode	14
DMX Channel Values In-Depth	15
5. Appendix	18
A Quick DMX Lesson	18
Keeping Your Stiletto™ Z18 As Good As New	19
Returns (Gasp!)	19
Shipping Issues	19
Troubleshooting	19
Tech Specs	20
Dimensional Drawings	21

1. GETTING STARTED

What's In The Box?

- 1 x Stiletto™ Z18 Moving Head Fixture
- 1 x Mounting Bracket
- An Ever-So-Handy Power Cord
- This Lovely User Manual

Getting It Out Of The Box

Congratulations! You have just purchased one super-sharp, super tasty quad-color RGBW moving head fixture that is bursting with flavor! So now that you're the proud owner of a Stiletto™ Z18 (or hopefully, *Stiletto!*), you should carefully unpack the box and check the contents to ensure that all parts are present and in good condition. If anything looks as if it has been damaged in transit, notify the shipper immediately and keep the packing material for inspection. Again, please save the carton and all packing materials. If a fixture must be returned to the factory, it is important that the fixture be returned in the original factory box and packing.

Powering Up!

All fixtures must be powered directly off a switched circuit and **cannot be run off a rheostat (variable resistor) or dimmer circuit, even if the rheostat or dimmer channel is used solely for a 0% to 100% switch.**

AC Voltage Switch - Not all fixtures have a voltage select switch, so please verify that the fixture you receive is suitable for your local power supply. See the label on the fixture or refer to the fixture's specifications chart for more information. A fixture's listed current rating is its average current draw under normal conditions. Check the fixture or device carefully to make sure that if a voltage selection switch exists that it is set to the correct line voltage you will use.

Warning! Verify that the voltage select switch on your unit matches the line voltage applied. Damage to your fixture may result if the line voltage applied does not match the voltage indicated on the voltage selector switch. All fixtures must be connected to circuits with a suitable Ground (Earthing).

Getting A Hold Of Us

If something happens goes wrong, please visit www.blizzardlighting.com/support and open a support ticket. We'll be happy to help, honest.

Blizzard Lighting
N24 W23750 Watertown Rd. Suite B
Waukesha, WI 53188 USA
www.blizzardlighting.com

Disclaimer: The information and specifications contained in this document are subject to change without notice. Blizzard Lighting™ assumes no responsibility or liability for any errors or omissions that may appear in this user manual. Blizzard Lighting™ reserves the right to update the existing document or to create a new document to correct any errors or omissions at any time. You can download the latest version of this document from www.blizzardlighting.com.

Author:	Date:	Last Edited:	Date:
J. Thomas	12/7/2015	J. Thomas	12/7/2015

SAFETY INSTRUCTIONS



Please read these instructions carefully. They include important information about the installation, usage and maintenance of this product.

- Please keep this User Guide for future use. If you sell the unit to someone else, be sure that they also receive this User Guide.
- ALWAYS make sure that you are connecting to the proper voltage, and that the line voltage you are connecting to is not higher than that stated on the decal or rear panel of the fixture.
- This product is intended for indoor use only.
- To prevent risk of fire or shock, do not expose fixture to rain or moisture.
- Make sure there are no flammable materials close to the unit while operating.
- The unit must be installed in a location with adequate ventilation, at least 20in (50cm) from adjacent surfaces. Be sure that no ventilation slots are blocked.
- ALWAYS disconnect from the power source before servicing or replacing fuse and be sure to replace with same fuse size and type.
- ALWAYS secure fixture using a safety chain. NEVER carry the fixture by its cord. Use its carrying handles.
- DO NOT operate at ambient temperatures higher than 104°F (40°C).
- In the event of a serious operating problem, stop using the unit immediately. NEVER try to repair the unit by yourself. Repairs carried out by unskilled people can lead to damage or malfunction. Please contact the nearest authorized technical assistance center. Always use the same type spare parts.
- NEVER connect the device to a dimmer pack.
- Make sure the power cord is never crimped or damaged.
- Never disconnect the power cord by pulling or tugging on the cord.
- Avoid direct eye exposure to the light source while it is on.

Caution! There are no user serviceable parts inside the unit. Do not open the housing or attempt any repairs yourself. In the unlikely event your unit may require service, please contact Blizzard Lighting at www.blizzardlighting.com/support.

2. MEET THE STILETTO™ Z18 MOVING HEAD™

MAIN FEATURES:

- 18* multi-chip 4-in-1 RGBW 15W LEDs
- 6-segment RGBW color mixing with stunning effects
- 6.5°-60° degree zoomable beam angle
- Individually controllable LED segments
- 8/16-bit pan and tilt (360°/540° pan, 270° tilt)
- Four user selectable dimming curve modes via DMX
- Smooth 0-100% dimming, flicker free
- Built-in automated programs via master/slave
- Built-in sound activated programs via master/slave
- PowerCon™ compatible AC power In/Out connectors

CONTROL:

- USITT DMX-512 (20/40-channels)
- 3/5-pin DMX In/Out
- 4-button menu with LCD display

DMX Quick Reference (20/40-Channel Mode)

Standard 20 Ch.	Zone/Shape 40 Ch.	What is does
1	1	Pan (0-360/540 degree)
2	2	Fine Pan
3	3	Tilt (0-270 degree)
4	4	Fine Tilt
5	5	Pan/Tilt Speed (fast <--> slow)
6	6	Strobe (slow <--> fast)
7	7	Dimmer (0% <--> 100%)
8	8	Dimming Mode (1-4)
9	9	Zoom Adjustment (6.5° - 60°)
--	10-33	Individual Segment 1-6 R/G/B/W Color Mixing
10	--	Red Intensity (0% <--> 100%)
11	--	Green Intensity (0% <--> 100%)
12	--	Blue Intensity (0% <--> 100%)
13	--	White Intensity (0% <--> 100%)
14	34	Full colors and auto mode (slow <--> fast)
15	35	Color Presets/Patterns
16	36	Presets/Patterns Dimmer
17	37	Chase Patterns
18	38	Chase Speed
19	38	Chase Fade
20	40	Motor Reset

Figure 1: The Stiletto™ Z18 Pin-Up Picture



Figure 2: The Rear Connections

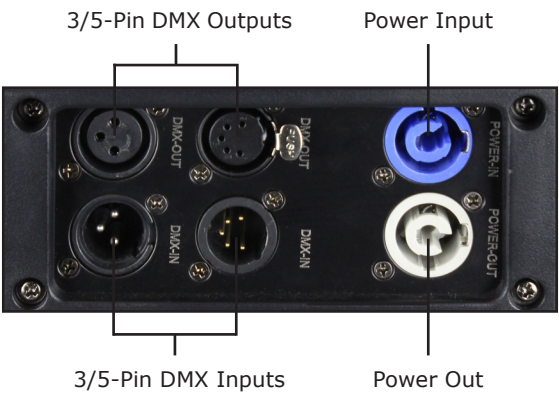

3. SETUP



Before replacing a fuse, disconnect power cord. ALWAYS replace with the same type and rating of fuse.

Fuse Replacement

CAUTION! The Stiletto™ Z18 utilizes a high-output switch-mode power supply with an internal fuse. Under normal operating conditions, the fuse should not require replacement. The fuse is field replaceable, however it is an advanced procedure suited to qualified individuals. Should your fixture require replacement, please contact Blizzard Lighting for instructions, or to return your unit for service.

Connecting A Bunch of Stiletto™ Z18 Fixtures

You will need a serial data link to run light shows using a DMX-512 controller or to run shows on two or more fixtures set to sync in master/slave operating mode. The combined number of channels required by all the fixtures on a serial data link determines the number of fixtures the data link can support.

Fixtures on a serial data link must be daisy chained in one single line. Also, connecting more than 32 fixtures on one serial data link without the use of a DMX optically-isolated splitter may result in deterioration of the digital DMX signal.

The maximum recommended cable-run distance is 500 meters (1640 ft). The maximum recommended number of fixtures on a serial data link is 32 fixtures.

Data/DMX Cabling

To link fixtures together you'll need data cables. You should use data-grade cables that can carry a high quality signal and are less prone to electromagnetic interference.

For instance, Belden© 9841 meets the specifications for EIA RS-485 applications. Standard microphone cables will "probably" be OK, but note that they cannot transmit DMX data as reliably over long distances. In any event, the cable should have the following characteristics:

2-conductor twisted pair plus a shield
Maximum capacitance between conductors – 30 pF/ft.
Maximum capacitance between conductor & shield – 55 pF/ft.
Maximum resistance of 20 ohms / 1000 ft.
Nominal impedance 100 – 140 ohms

Cable Connectors

Cables must have a male XLR connector on one end and a female XLR connector on the other end. (Duh!)

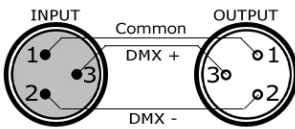

A Word on Termination: DMX is a resilient communication protocol, however errors still occasionally occur. Termination reduces signal errors, and therefore best practices include use of a terminator in all circumstances. If you are experiencing problems with erratic fixture behavior, especially over long signal cable runs, a terminator may help improve performance.

To build your own DMX Terminator:
Obtain a 120-ohm, 1/4-watt resistor, and wire it between pins 2 & 3 of the last fixture. They are also readily available from specialty retailers.

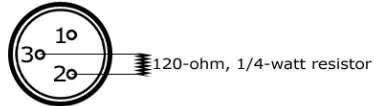

CAUTION: Do not allow contact between the common and the fixture's chassis ground. Grounding the common can cause a ground loop, and your fixture may perform erratically. Test cables with an ohm meter to verify correct polarity and to make sure the pins are not grounded or shorted to the shield or each other.

3-Pin??? 5-Pin??? Huh?!?

If you use a controller with a 5 pin DMX output connector, you will need to use a 5 pin to 3 pin adapter. They are widely available over the internet and from specialty retailers. If you'd like to build your own, the chart below details a proper cable conversion:

Conductor	3-Pin Female (Output)	5-Pin Male (Input)
Ground/Shield	Pin 1	Pin 1
DMX Data (-)	Pin 2	Pin 2
DMX Data (+)	Pin 3	Pin 3
Not Used.	No Connection.	No Connection.
Not Used.	No Connection.	No Connection.

Take It To The Next Level: Setting Up DMX Control

Step 1: Connect the male connector of the DMX cable to the female connector (output) on the controller.



Step 2: Connect the female connector of the DMX cable to the first fixture's male connector (input). *Note:* It doesn't matter which fixture address is the first one connected. We recommend connecting the fixtures in terms of their proximity to the controller, rather than connecting the lowest fixture number first, and so on.

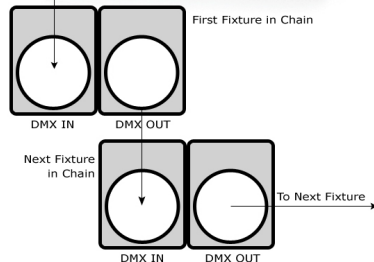

Step 3: Connect other fixtures in the chain from output to input as above. Place a DMX terminator on the output of the final fixture to ensure best communication.

Fixture Linking (Master/Slave Mode)

1. Connect the (male) 3/5-pin connector side of the DMX cable to the output (female) 3/5-pin connector of the first fixture.
2. Connect the end of the cable coming from the first fixture which will have a (female) 3/5-pin connector to the input connector of the next fixture consisting of a (male) 3/5-pin connector. Then, proceed to connect from the output as stated above to the input of the following fixture and so on.

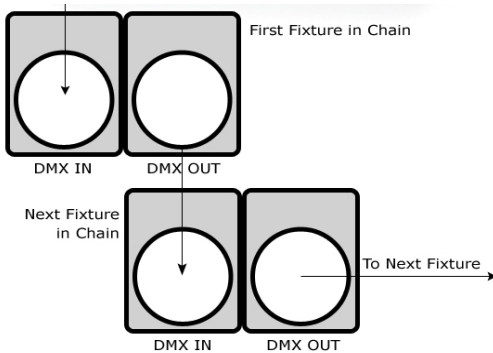

A quick note: Often, the setup for Master-Slave and Standalone operation requires that the first fixture in the chain be initialized for this purpose via either settings in the control panel or DIP-switches. Secondly, the fixtures that follow may also require a slave setting.

Check the **"Operating Adjustments"** section in this manual for complete instructions for this type of setup and configuration.

Mounting & Rigging

This fixture may be mounted in any SAFE position provided there is enough room for ventilation.

It is important never to obstruct the fan or vents pathway. Mount the fixture using a suitable "C" or "O" type clamp. The clamp should be rated to hold at least 10x the fixture's weight to ensure structural stability. Do not mount to surfaces with unknown strength, and ensure properly "rated" rigging is used when mounting fixtures overhead.

Adjust the angle of the fixture by loosening both knobs and tilting the fixture. After finding the desired position, retighten both knobs.

- When selecting installation location, take into consideration access for routine maintenance.
- Safety cables **MUST ALWAYS** be used.
- Never mount in places where the fixture will be exposed to rain, high humidity, extreme temperature changes or restricted ventilation.

Mounting Points

Overhead mounting requires extensive experience, which includes calculating working load limits, knowledge of the installation material being used, and periodic safety inspection of all installation material and the fixture. If you lack these qualifications, do not attempt the installation yourself. Improper installation can result in bodily injury.

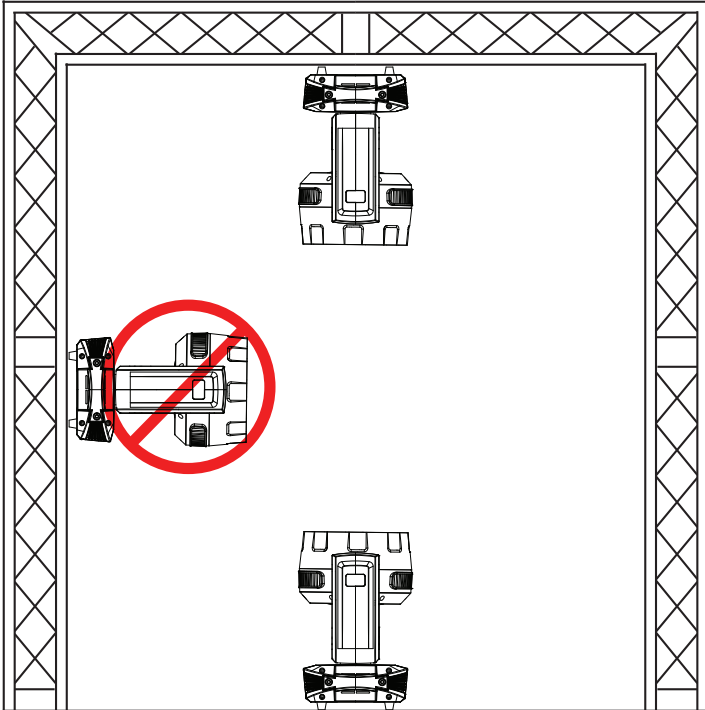

Caution!

Please be aware, you should have a qualified electrician performing all of your electrical connection needs. Better safe than sorry!

Be sure to complete all rigging and installation procedures before connecting the main power cord to the appropriate wall outlet.

Clamp Mounting

This fixture provides a mounting bracket assembly that secures the bottom of the base, the "Omega Bracket," and the safety cable rigging point together. When mounting this fixture to truss, be sure to secure an appropriately rated clamp to the omega bracket using an M10 screw fitted through the center hole of the "omega bracket".

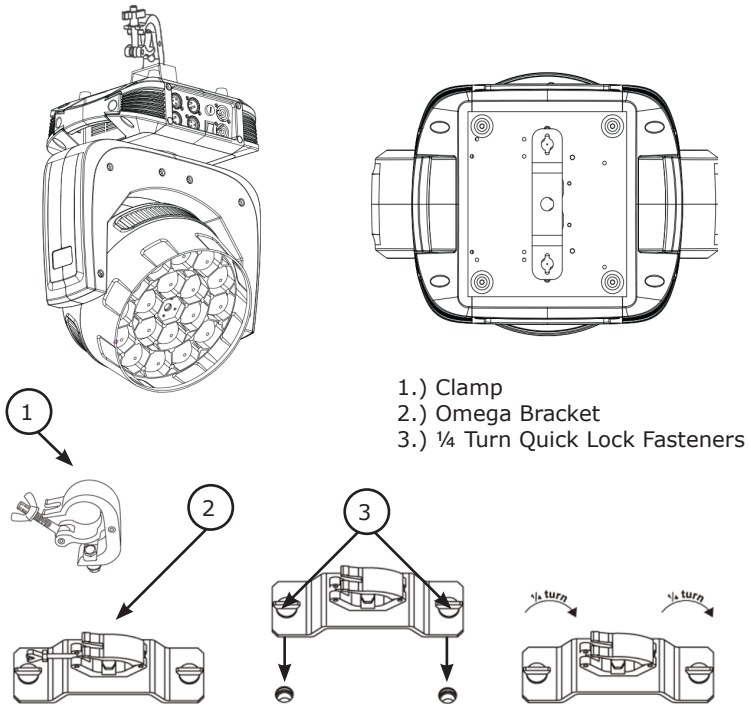

Securing the Fixture

Regardless of the rigging option you choose for your fixtures always be sure to secure your fixture with a safety cable.

4. OPERATING ADJUSTMENTS

The Control Panel

All the goodies and different modes possible with the Stiletto™ Z18 are accessed by using the control panel on the front of the fixture. There are 4 control buttons below the LCD display which allow you to navigate through the various control panel menus.

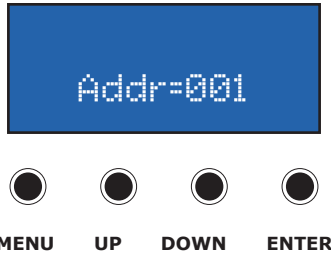

Button	Function
<MENU>	Used to access the menu or to return to a previous menu option.
<UP>	Scrolls through menu options in ascending order.
<DOWN>	Scrolls through menu options in descending order.
<ENTER>	Used to select and store the current menu or option within a menu.

Access control panel functions using the four panel buttons located directly underneath the LCD Display.

The Control Panel LCD Display shows the menu items you select from the menu map on page #13. When a menu function is selected, the display will show immediately the first available option for the selected menu function. To select a menu item, press **<ENTER>**.

Use the **<UP>** and **<DOWN>** buttons to navigate the menu map and menu options. Press the **<ENTER>** button to access the menu function currently displayed or to enable a menu option. To return to the previous option or menu without changing the value, press the **<MENU>** button.

Control Panel Menu Structure

Main Function	Sub Function	Selection	What It Does...	
Function 1	Address	=000 <-> XXX	Sets the DMX address	
	CH Value	= XXX...	Displays all current DMX channel values	
	Slave	= Slave	Sets the unit in slave mode.	
	Auto	= Alone = Master	Sets the unit in auto mode	
	Music	= Alone = Master	Sets the unit in sound active mode	
Info 2	Temp Inf	Head Tem	= XXX	Displays the current internal temperature
	Soft Inf		= OFF / = ON	Displays the current software version
Person 3	Status	Pan Rev	= OFF / = ON	Reverses the pan movement
		Tilt Rev	= OFF / = ON	Reverses the tilt movement
		P-Degree	=360 <-> 540	Pan rotation (360° or 540°)
		M Speed	Speed 1 / 2	Adjust Motor Speed (1=fast, 2=slow)
		Mic Sens	= 0% / = 99%	Adjust the sound active mic sensitivity
	Temp C/F		= F / = C	Display degrees as Fahrenheit or Celsius
	Default		= OFF / = ON	Resets personalized settings to default
Reset 4	Reset?	<ENTER>	Resets the fixture	
Adjust 5	Password	=000 <-> 255	Password protected pan/tilt calibration settings. The password is: 050	
Mode Set 6	Standard	<ENTER>	Set the fixture to 20ch DMX mode	
	Shape	<ENTER>	Set the fixture to 40ch DMX mode	

DMX Mode

Allows the unit to be controlled by any universal DMX controller.

Set The DMX Starting Address

- 1.) To assign a DMX starting address to the fixture, use the <UP/DOWN> buttons to scroll to **Function**, and press the <ENTER> button. Then use the <UP/DOWN> buttons to display **Address**, press <ENTER>, and use the <UP/DOWN> buttons to highlight any value desired for the starting DMX address. Press the <ENTER> button to confirm your choice.

DMX Channel Mode

- 1.) To select a DMX channel mode that you wish to work in, use the <UP/DOWN> buttons to scroll to **Mode Set**, and press <ENTER>. Press the <ENTER> button again, and then use the <UP/DOWN> buttons to display either **Standard** (20ch mode) or **Shape** (40ch mode), and push the <ENTER> button to confirm your choice.

Slave Mode

- 1.) Disconnect fixture(s) from DMX signal source, and set all to matching DMX channel modes.
- 2.) For each fixture you want to run in slave mode, use the <UP/DOWN> buttons to navigate to **Function**, and press <ENTER>. Then use the <UP/DOWN> buttons to navigate to **Slave**, and press <ENTER> to confirm.
- 3.) Connect all fixtures together via DMX. The first fixture in the DMX chain will be the master fixture, followed by the slave fixtures.
- 4.) Connect DMX controller to the master unit for DMX control.

Personal (Customized) Settings

1.) For manual/customized settings, navigate the control panel menu to highlight **Person**, and press **<ENTER>**. Use the **<UP/DOWN>** buttons to highlight **Status** then press **<ENTER>**. From here you can use the **<UP/DOWN>** buttons to turn on/off reverse pan (**Pan Rev**), or reverse tilt (**Tilt Rev**), choose the pan rotation level of either 360° or 540° (**P-Degree**), adjust the motor speed to fast or slow (**M Speed**), and adjust the internal mic sensitivity level from 0-99% (**Mic Sens**). When you are finished, press **<ENTER>** to confirm your changes.

Revert Custom Settings

1.) To revert customized settings back to the factory default, navigate the top level menu to reach **Person**, and press **<ENTER>**. Then use the **<UP/DOWN>** buttons to highlight **Default**, and press the **<ENTER>** button.
2.) Highlight **YES**, then press **<ENTER>**.

Auto, Stand-Alone, Sound Active Modes:

Allows a single or Master/Slaved units to run factory installed programs at user selectable speeds.

Auto Mode

1.) Use the **<UP/DOWN>** button to scroll to **Function**, and press **<ENTER>**. Now use the **<UP/DOWN>** buttons to highlight **Auto** (Alone or Master), and press the **<ENTER>** button.
2.) You can now adjust the *motor speed* if you like by navigating the top level menu to **Person**, and press **<ENTER>**. Then use the **<UP/DOWN>** buttons to highlight **Status**, and press the **<ENTER>** button.
3.) From here, use the **<UP/DOWN>** buttons to highlight **M Speed**, press **<ENTER>**, then use the **<UP/DOWN>** buttons again to choose either **Speed 1** (fast), or **Speed 2** (slow).
4.) Press **<ENTER>** to confirm.

Sound Active Mode

1.) Use the **<UP/DOWN>** button to scroll to **Function**, and press **<ENTER>**. Now use the **<UP/DOWN>** buttons to highlight **Music** (Alone or Master), and press the **<ENTER>** button.
2.) You can now adjust the *mic sensitivity* if you like by navigating the top level menu to **Person**, and press **<ENTER>**. Use the **<UP/DOWN>** buttons to highlight **Status**, and press the **<ENTER>** button.
3.) From here, use the **<UP/DOWN>** buttons to highlight **Mic Sens**, press **<ENTER>**, then use the **<UP/DOWN>** buttons to choose a percentage level from **0%** (off), to **99%** (highest level).
4.) Press **<ENTER>** to confirm

DMX Values In-Depth (20/40-Channel Mode)

20Ch Mode	40Ch Mode	Value	What is does
1	1	000 <--> 255	Pan (0-540 degree)
2	2	000 <--> 255	Fine Pan
3	3	000 <--> 255	Tilt (0-270 degree)
4	4	000 <--> 255	Fine Tilt
5	5	000 <--> 225 226 <--> 255	Pan/Tilt Speed Pan/Tilt Speed (fast <--> slow) No Function
6	6	000 <--> 255	Strobe (slow <--> fast)
7	7	000 <--> 255	Dimmer (0% <--> 100%)
8	8	000 <--> 049 050 <--> 099 100 <--> 149 150 <--> 255	32-bit Dimming Modes Dimming Mode 1 Dimming Mode 2 Dimming Mode 3 Dimming Mode 4
9	9	000 <--> 255	Zoom Adjustment (narrow <--> wide)
10	--	000 <--> 255	Red Intensity (0% <--> 100%)
11	--	000 <--> 255	Green Intensity (0% <--> 100%)
12	--	000 <--> 255	Blue Intensity (0% <--> 100%)
13	--	000 <--> 255	White Intensity (0% <--> 100%)
--	10	000 <--> 255	Segment 1 - Red Intensity (0% <--> 100%)
--	11	000 <--> 255	Segment 1 - Green Intensity (0% <--> 100%)
--	12	000 <--> 255	Segment 1 - Blue Intensity (0% <--> 100%)
--	13	000 <--> 255	Segment 1 - White Intensity (0% <--> 100%)
--	14	000 <--> 255	Segment 2 - Red Intensity (0% <--> 100%)
--	15	000 <--> 255	Segment 2 - Green Intensity (0% <--> 100%)
--	16	000 <--> 255	Segment 2 - Blue Intensity (0% <--> 100%)
--	17	000 <--> 255	Segment 2 - White Intensity (0% <--> 100%)
--	18	000 <--> 255	Segment 3 - Red Intensity (0% <--> 100%)
--	19	000 <--> 255	Segment 3 - Green Intensity (0% <--> 100%)
--	20	000 <--> 255	Segment 3 - Blue Intensity (0% <--> 100%)
--	21	000 <--> 255	Segment 3 - White Intensity (0% <--> 100%)
--	22	000 <--> 255	Segment 4 - Red Intensity (0% <--> 100%)
--	23	000 <--> 255	Segment 4 - Green Intensity (0% <--> 100%)
--	24	000 <--> 255	Segment 4 - Blue Intensity (0% <--> 100%)
--	25	000 <--> 255	Segment 4 - White Intensity (0% <--> 100%)
--	26	000 <--> 255	Segment 5 - Red Intensity (0% <--> 100%)
--	27	000 <--> 255	Segment 5 - Green Intensity (0% <--> 100%)
--	28	000 <--> 255	Segment 5 - Blue Intensity (0% <--> 100%)
--	29	000 <--> 255	Segment 5 - White Intensity (0% <--> 100%)
--	30	000 <--> 255	Segment 6 - Red Intensity (0% <--> 100%)
--	31	000 <--> 255	Segment 6 - Green Intensity (0% <--> 100%)
--	32	000 <--> 255	Segment 6 - Blue Intensity (0% <--> 100%)
--	33	000 <--> 255	Segment 6 - White Intensity (0% <--> 100%)

DMX Values In-Depth (20/40-Channel Mode), Continued

20Ch Mode	40Ch Mode	Value	What it does
14	34	000 <--> 004 005 <--> 029 030 <--> 054 055 <--> 079 080 <--> 104 105 <--> 129 130 <--> 154 155 <--> 174 175 <--> 179 180 <--> 184 185 <--> 189 190 <--> 210 211 <--> 255	Full Colors and Auto Mode No function Red Green Blue White Mixed Color 1 Mixed Color 2 Mixed Color 3 Mixed Color 4 Mixed Color 5 Mixed Color 6 Mixed Color 7 Auto - crossfading full colors (slow <--> fast)
15	35	000 <--> 004 005 <--> 009 010 <--> 014 015 <--> 019 020 <--> 024 025 <--> 029 030 <--> 034 035 <--> 039 040 <--> 044 045 <--> 049 050 <--> 054 055 <--> 059 060 <--> 064 065 <--> 069 070 <--> 074 075 <--> 079 080 <--> 084 085 <--> 089 090 <--> 094 095 <--> 099 100 <--> 104 105 <--> 109 110 <--> 114 115 <--> 119 120 <--> 124 125 <--> 129 130 <--> 134 135 <--> 139 140 <--> 144 145 <--> 149 150 <--> 154 155 <--> 159 160 <--> 164 165 <--> 169 170 <--> 255	Color Presets and Patterns No function White 1 White 2 White 3 White 4 White 5 White 6 Red Green Blue White Mixed Color 1 Mixed Color 2 Mixed Color 3 Mixed Color 4 Mixed Color 5 Mixed Color 6 Mixed Color 7 Mixed Color 8 Mixed Color 9 Mixed Color 10 Mixed Color 11 Mixed Color 12 Sectional Color Pattern 1 Sectional Color Pattern 2 Sectional Color Pattern 3 Sectional Color Pattern 4 Sectional Color Pattern 5 Sectional Color Pattern 6 Sectional Color Pattern 7 Sectional Color Pattern 8 Sectional Color Pattern 9 Sectional Color Pattern 10 Sectional Color Pattern 11 Reserved
16	36	000 <--> 255	Preset Color Dimmer (100% <--> 0%)

DMX Values In-Depth (20/40-Channel Mode), Continued

20Ch Mode	40Ch Mode	Value	What it does
17	37	001 <--> 014 015 <--> 030 031 <--> 046 047 <--> 062 063 <--> 078 079 <--> 094 095 <--> 110 111 <--> 126 127 <--> 142 143 <--> 158 159 <--> 174 175 <--> 190 191 <--> 206 207 <--> 222 223 <--> 238 239 <--> 255	Chase Patterns LEDs turn off Chase 1 Chase 2 Chase 3 Chase 4 Chase 5 Chase 6 Chase 7 Chase 8 Chase 9 Chase 10 Chase 11 Chase 12 Chase 13 Chase 14 Chase 15
18	38	000 <--> 125 126 <--> 130 131 <--> 255	Chase Speed Clockwise rotation (fast <--> slow) Stop Counterclockwise rotation (slow <--> fast)
19	39	000 <--> 255	Chase Fade
20	40	000 <--> 079 080 <--> 099 100 <--> 255	Motor Reset No function All motors reset No function

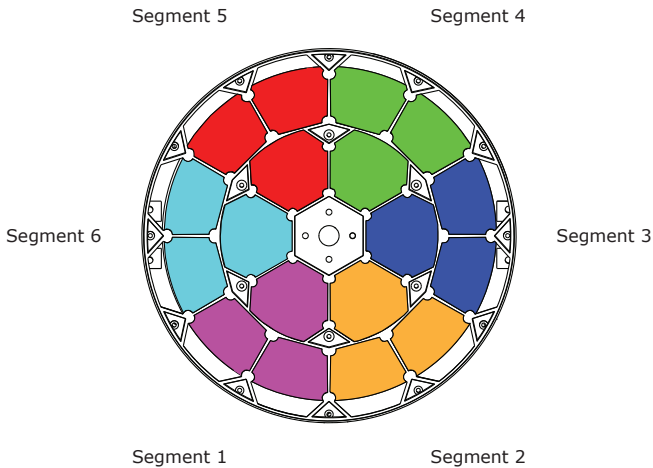

5. APPENDIX

A Quick Lesson On DMX

DMX (aka DMX-512) was created in 1986 by the United States Institute for Theatre Technology (USITT) as a standardized method for connecting lighting consoles to lighting dimmer modules. It was revised in 1990 and again in 2000 to allow more flexibility. The Entertainment Services and Technology Association (ESTA) has since assumed control over the DMX512 standard. It has also been approved and recognized for ANSI standard classification.

DMX covers (and is an abbreviation for) Digital MultipleXed signals. It is the most common communications standard used by lighting and related stage equipment.

DMX provides up to 512 control "channels" per data link. Each of these channels was originally intended to control lamp dimmer levels. You can think of it as 512 faders on a lighting console, connected to 512 light bulbs. Each slider's position is sent over the data link as an 8-bit number having a value between 0 and 255. The value 0 corresponds to the light bulb being completely off while 255 corresponds to the light bulb being fully on.

DMX data is transmitted at 250,000 bits per second using the RS-485 transmission standard over two wires. As with microphone cables, a grounded cable shield is used to prevent interference with other signals.

There are five pins on a DMX connector: a wire for ground (cable shield), two wires for "Primary" communication which goes from a DMX source to a DMX receiver, and two wires for a "Secondary" communication which goes from a DMX receiver back to a DMX source. Generally, the "Secondary" channel is not used so data flows only from sources to receivers. Hence, most of us are most familiar with DMX-512 as being employer over typical 3-pin "mic cables," although this does not conform to the defined standard.

DMX is connected using a daisy-chain configuration where the source connects to the input of the first device, the output of the first device connects to the input of the next device, and so on. The standard allows for up to 32 devices on a single DMX link.

Each receiving device typically has a means for setting the "starting channel number" that it will respond to. For example, if two 6-channel fixtures are used, the first fixture might be set to start at channel 1 so it would respond to DMX channels 1 through 6, and the next fixture would be set to start at channel 7 so it would respond to channels 7 through 12.

The greatest strength of the DMX communications protocol is that it is very simple and robust. It involves transmitting a reset condition (indicating the start of a new "packet"), a start code, and up to 512 bytes of data. Data packets are transmitted continuously. As soon as one packet is finished, another can begin with no delay if desired (usually another follows within 1 ms). If nothing is changing (i.e. no lamp levels change) the same data will be sent out over and over again. This is a great feature of DMX -- if for some reason the data is not interpreted the first time around, it will be re-sent shortly.

Not all 512 channels need to be output per packet, and in fact, it is very uncommon to find all 512 used. The fewer channels are used, the higher the "refresh" rate. It is possible to get DMX refreshes at around 1000 times per second if only 24 channels are being transmitted. If all 512 channels are being transmitted, the refresh rate is around 44 times per second.

In summary, since its design and evolution in the 1980's DMX has become the standard for lighting control. It is flexible, robust, and scalable, and its ability to control everything from dimmer packs to moving lights to foggers to lasers makes it an indispensable tool for any lighting designer or lighting performer.

Keeping Your Stiletto™ Z18 As Good As New

The fixture you've received is a rugged, tough piece of pro lighting equipment, and as long as you take care of it, it will take care of you. That said, like anything, you'll need to take care of it if you want it to operate as designed. You should absolutely keep the fixture clean, especially if you are using it in an environment with a lot of dust, fog, haze, wild animals, wild teenagers or spilled drinks.

Cleaning the optics routinely with a suitable glass cleaner will greatly improve the quality of light output. Keeping the fans free of dust and debris will keep the fixture running cool and prevent damage from overheating.

In transit, keep the fixtures in cases. You wouldn't throw a prized guitar, drumset, or other piece of expensive gear into a gear trailer without a case, and similarly, you shouldn't even think about doing it with your shiny new light fixtures.

Common sense and taking care of your fixtures will be the single biggest thing you can do to keep them running at peak performance and let you worry about designing a great light show, putting on a great concert, or maximizing your client's satisfaction and "wow factor." That's what it's all about, after all!

Returns (Gasp!)

We've taken a lot of precautions to make sure you never even have to worry about sending a defective unit back, or sending a unit in for service. But, like any complex piece of equipment designed and built by humans, once in a while, something doesn't go as planned. If you find yourself with a fixture that isn't behaving like a good little fixture should, you'll need to obtain a Return Authorization (RA).

Don't worry, this is easy. Just visit www.blizzardlighting.com/support and open a support ticket, and we'll issue you an RA. Then, you'll need to send the unit to us using a trackable, pre-paid freight method. We suggest using USPS Priority or UPS. Make sure you carefully pack the fixture for transit, and whenever possible, use the original box & packing for shipping.

When returning your fixture for service, be sure to include the following:

- 1.) Your contact information (Name, Address, Phone Number, Email address).
- 2.) The RA# issued to you
- 3.) A brief description of the problem/symptoms.

We will, at our discretion, repair or replace the fixture. Please remember that any shipping damage which occurs in transit to us is the customer's responsibility, so pack it well!

Shipping Issues

Damage incurred in shipping is the responsibility of the shipper, and must be reported to the carrier immediately upon receipt of the items. Claims must be made within seven (7) days of receipt.

Troubleshooting

Symptom	Solution
Fixture Auto-Shut Off	Check the fan in the fixture. If it is stopped or moving slower than normal, the unit may have shut itself off due to high heat. This is to protect the fixture from overheating. Clear the fan of obstructions, or return the unit for service.
Beam is Dim	Check optical system and clean excess dust/grime. Also ensure that the 220V/110V switch is in the correct position, if applicable.
No Light Output	Check to ensure fixture is operating under correct mode, IE sound active/auto/DMX/Etc., if applicable. Contact service for more information.
Chase Speed Too Fast/Slow	Check to ensure proper setup of speed adjustment.
No Power	Check fuse, AC cord and circuit for malfunction.
No Response to Audio	Verify that the fixture is in "Sound Active" mode. Adjust Audio Sensitivity, If Applicable.
Fixture Not Responding / Responding Erratically	Make sure all connectors are seated properly and securely. Use Only DMX Cables. Install a Terminator. Check all cables for defects. Reset fixture(s).

Tech Specs!

Weight & Dimensions	
Width	13.5 in (34.3 cm)
Depth	9.5 in (24.1 cm)
Height	16.5 in (41.9 cm)
Weight	22 lbs (10 kg)
Power	
Operating Voltage	AC 100-240VAC, 50-60 Hertz
Power Consumption	305W, 2.55A
Power Factor	.99
Light Source	
LED	18x multi-chip 4-in-1 RGBW 15W LEDs
Optical	
Beam Angle	6.5°-60° zoomable beam angle
Luminous Intensity	28,091 Lux @ 2m (narrow) 6,705 Lux @ 5m (narrow) 1,967 Lux @ 2m (wide)
Thermal	
Max. Operating Temp.	104 degrees F (40 degrees C) ambient
Control	
Protocol	USITT DMX-512
DMX Channels	20/40 Channels
Input	3/5-pin XLR Male
Output	3/5-pin XLR Female
Other Operating Modes	Standalone, Master/Slave, Auto, Sound Active
Other Information	
I'm counting on you, fingers.	
Warranty	2-year limited warranty, does not cover malfunction caused by damage to LEDs.

DISCLAIMER:

The power connector fitted to the fixture and fixture cord are designed for compatibility with products manufactured by Neutrik AG, Neutrik USA and their related entities, however they are not manufactured by, affiliated with or endorsed by Neutrik AG, Neutrik USA, or any related entity. Neutrik® and powerCON® are registered trademarks of Neutrik AG.

Dimensional Drawings

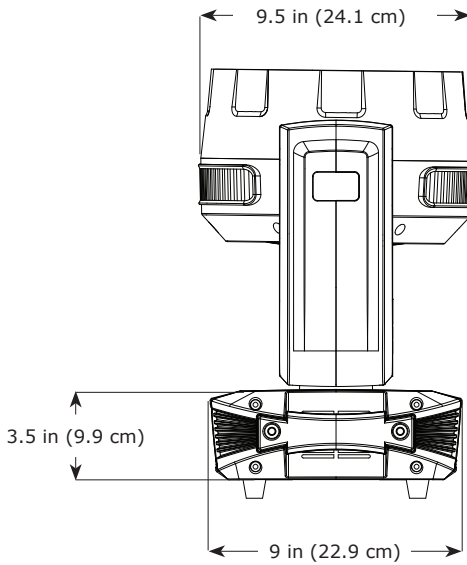
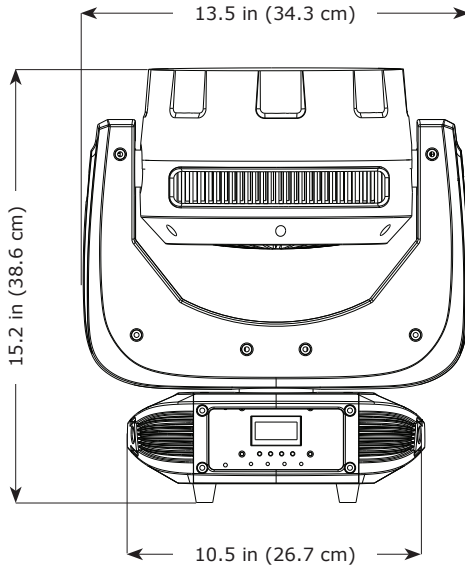

This page is intentionally left blank.

This page is intentionally left blank.



**Enjoy your product!
Our sincerest thanks for your purchase!
--The team @ Blizzard Lighting**